

SCP250G5

**SANY**

Quality Changes the World

# AGILE HIGH- PERFORMANCE VEHICLE

POWERFUL. ROBUST. RELIABLE.



**HEAVY-DUTY FORKLIFT**  
**SCP250G5**

Lifting capacity  
25 000 kg  
Engine  
VOLVO TAD881VE  
Emission standard  
EU Stage V  
Rated power  
185 kW

**Performance comes from quality.  
Quality comes from experience.**

SANY Europe is part of the SANY Group, a globally leading manufacturer of construction machinery, forklift trucks, port equipment and wind turbines. Our aim is always to deliver products that are tailored to the national market concerned. Equipped with high-performance, innovative technology. Because we are responsible for our own steel production and we design and manufacture our rear axles and box chassis in-house, we are able to set our own high quality standards. What is more, our Europe-wide dealer network ensures that users can receive competent support for sales, service and maintenance on site.

**5-7%**  
FROM REVENUE AS AN INVESTMENT  
FOR RESEARCH AND DEVELOPMENT  
TO  
**5 YEARS\***  
WARRANTY\*

Quality Changes the World

\* Only from participating dealers

**SCP250G5  
HARD FACTS**

Lifting capacity  
25 000 kg

Lifting speed  
350 mm/s

Lowering  
speed  
500 mm/s

Max. travel  
speed  
29 km/h



## MOVING HEAVY LOADS SAFELY WITH PRECISION

When it comes to lifting heavy cargo, SANY's heavy-duty forklift is in its element. At the port, sawmill or steel manufacture, loading precast concrete components or wind energy components – it will do a stellar job wherever loads need to be moved and positioned with precision. The box frame, which is manufactured in-house, makes it particularly robust, and, thanks to its

tried-and-tested components, it is right at home in continuous use under the toughest of operating conditions. Its optimal weight distribution makes it highly stable. For agile manoeuvring, the double-action steering cylinder and the steering angle make for tight turns. The solid heavy-duty forklift combines precise, safe lifting, moving and positioning of cargo with low operating costs.



USER EXPERIENCE

# TAKING THE WEIGHT OFF OF HEAVY LOADS

The newly designed cab, which is now 40 mm wider, has a robust frame and offers an even safer and more comfortable workplace than the previous cab. For example, the operator will find powerful air conditioning with its own display for all AC settings in the cab as standard. The ergonomic joystick makes the fork functions particularly easy to use. The electric accelerator pedal and the combined braking/coupling pedal is responsible for quick, safe travel. The easy-to-tilt steering column makes getting in and out of the cab comfortable and underpins the optimised, ergonomic overall package.



USER EXPERIENCE

## Maintenance made easy

For easy access to the gear box, the driver's cab can be tilted to the right hydraulically.

Routine maintenance tasks can also be completed quickly thanks to the easily accessible lubrication points and a lubrication bench for hidden bearing points.



## Absolute reliability – for peace of mind!

SANY's warranty of up to 5 years\* gives you the assurance that you can fully count on your equipment.

\* Only from participating dealers

USER EXPERIENCE

## A complete overview

The large 10-inch display, which is easy to reach on the right-hand armrest console, is intuitive to use as a touch screen and includes a number of features, such as windscreen wipers, lights or on-board diagnostics. The forklift, mast tilt, fork spacing, fork side shift and individual fork spacing are controlled via the joystick – and that includes multiple operations at once.



### Our highlights – the added benefits SANY offers you:

- + Standard forks (250 mm wide, 110 mm high and 2400 mm long), ideal for fork recesses on 20 ft ISO containers
- + "Terminal-West" fork connection enables speedy switching between fork types (e.g. coil ram)
- + Optimal weight distribution and reduction of the front axle load for reduced wear on the tyres
- + High lifting speed for fast work
- + Powerful acceleration due to four-speed powershift gear box with torque converter and automatic gear shift

SAFETY

## Best outlook for safe working

The large opening in the middle of the mast offers a clear view of the fork and load at the front. The hydraulic lines arrangement on the mast is angled to minimise obstruction to the operator's view left and right of the mast. The rear window with its curved corners provides an unrestricted field of vision when reversing and manoeuvring. What is more, the large roof glazing offers a clear view of high masts – it is rare to see such an all-round view.

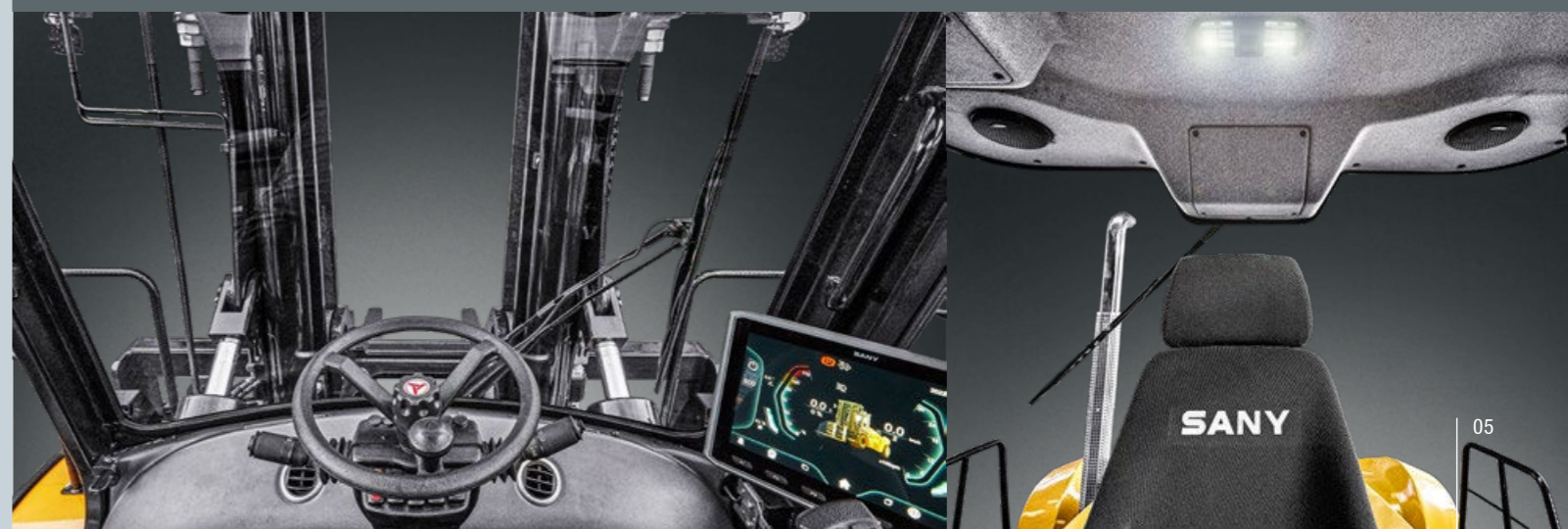

## ENGINE

Model	VOLVO TAD881VE
Rated power	185 kW / 2200 rpm
Emission	EU Stage V
Torque	1 160 Nm / 1 200 rpm
Displacement	7 700 cm

## GEARBOX

Gearbox type	DANA TE14
Forward/reverse gears	4F/4R

## DRIVING AND LIFTING PERFORMANCE

Lifting capacity	25 000 kg
Lifting speed without/with load	350 / 320 mm/s
Lowering speed without/with load	500 / 500 mm/s
Travel speed without/with load	29 / 28 km/h
Gradeability without/with load	42 / 25 %
Noise level inside cab	74 dB
Lifting height, standard	4 000 mm
Lifting height, optional	6 000 mm

## HYDRAULIC SYSTEM

Hydraulic oil tank	360 l
AdBlue tank	45 l
Fuel tank	400 l

## AXLES

Front axle	Kessler D91
------------	-------------

## AXLE LOAD

Front axle with load	54 153 kg
Rear axle with load	4 747 kg
Front axle without load	16 192 kg
Rear axle without load	17 708 kg

## TYRES

Tyre dimension	14.00-24
----------------	----------

## OPERATING MASS

SCP250G5	33 900 kg
----------	-----------

## DIMENSIONS

A Total length	8 791 mm
B Transport width	3 100 mm
C Transport height	3 960 mm
D Load centre	1 200 mm
E Wheel base	4 300 mm
F Front overhang	1 085 mm
G Rear overhang	1 005 mm
H Min. ground clearance	300 mm
I Seat height above ground	2 040 mm
J Inner turning radius	940 mm
K Outer turning radius	6 000 mm
L Front tyre track width	2 204 mm
M Rear tyre track width	2 450 mm

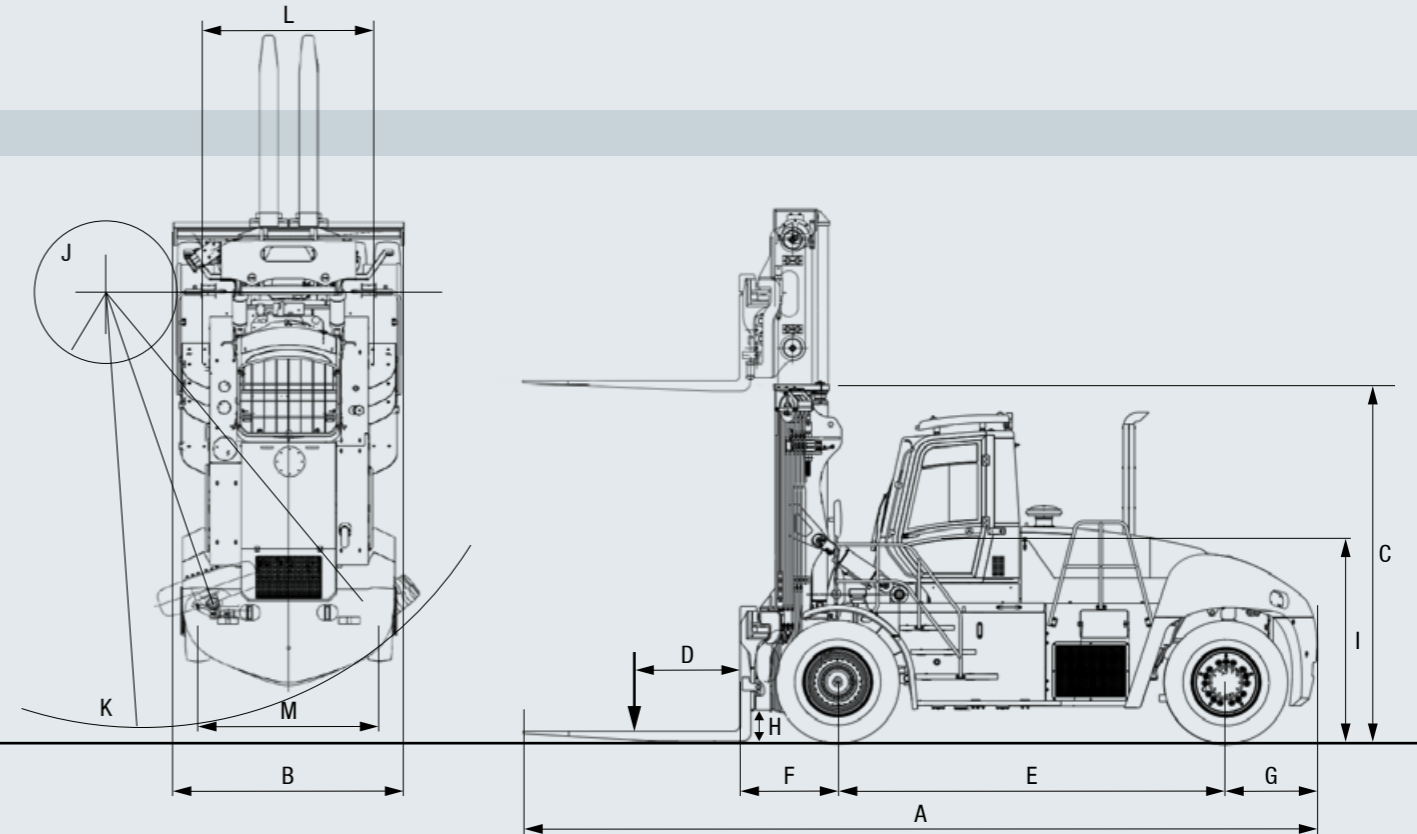

## LOAD CHART

The 1 200 mm load centre distance enables movement of containers and bulk goods as wide as a lorry.

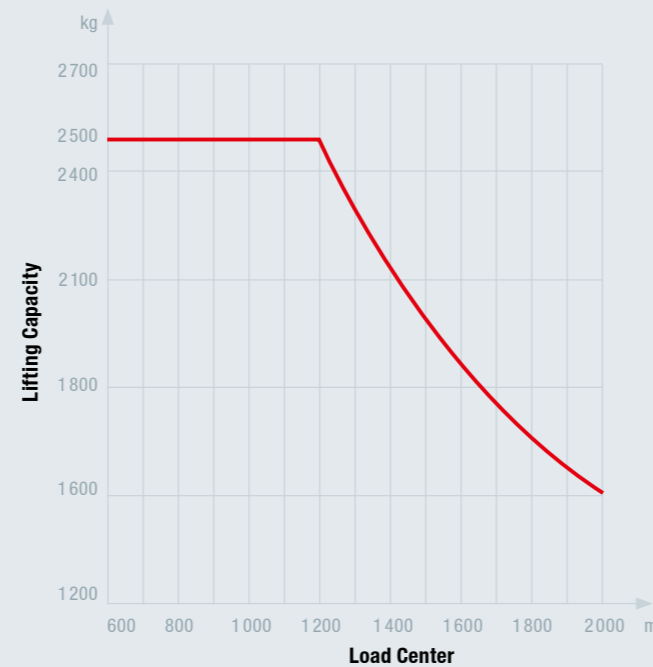

## FORKLIFT / MAST

Fork dimension (W x T x L) 250 x 110 x 2 400 mm



**Standard equipment – Fork carrier:**  
Robust, with easy-to-change fork arms, including side shift and fork positioning



**Optional – Other add-ons:**  
Coil ram and other add-ons available upon request



**Standard equipment – Duplex mast:**  
Ensures an excellent view



**Optional – Duplex mast with free lift:**  
On the duplex mast with free lift, lift cylinders are positioned to the side of the mast, giving an unrestricted view through the centre of the mast

## DUPLEX MASTS WITHOUT FREE LIFT

Lifting height	Mast height retracted	Mast height extended
3500 mm	3 710 mm	5 405 mm
4000 mm	3 960 mm	5 905 mm
4500 mm	4 210 mm	6 405 mm
5500 mm	4 710 mm	7 405 mm
6000 mm	4 960 mm	7 905 mm

## DUPLEX MASTS WITH FREE LIFT

Lifting height	Mast height retracted	Mast height extended	Free lift
4000 mm	3 960 mm	5 910 mm	2 050 mm

# EQUIPMENT **SCP250G5**

## More options for those with more in mind

SANY heavy-duty forklifts already come with a number of equipment features ex works. They can also be adapted to individual needs for a wide range of requirements and areas of application:



### OPERATING COMFORT/CAB

Air conditioning*	●
10" colour touch screen	●
Glass roof with sun-cover and protective grille	●
Comfortable driver's seat with high backrest	●
Air suspension, electrically adjustable lumbar supports and heated seats	●
Stationary, diesel-powered cabin heater	●
Winter package for electric pre-heating of the cabin, engine, diesel and hydraulic oil	●
Radio	●
Document holder, holder for tablet computer	●

### SAFETY

2 l fire extinguisher	●
Automatic reversing camera	●
Distance sensors at the rear	●
Tyre pressure monitoring	●
360° all-round camera system	●
Automatic fire extinguishing system in the engine compartment	●
Emergency stop switch on both sides of the machine	●
Adjustable speed limiter	●

### HYDRAULIC SYSTEM

Load-sensing hydraulic system	●
Automatic engine speed increase	●

Standard equipment ●      Option ●

\* The air-conditioning system contains fluorinated greenhouse gases: Refrigerant type: R134a, global warming potential: 1 300, quantity: 1.6 kg, CO<sub>2</sub>e: 2.08 tonnes

Not all products are available in all markets. As part of our continuous improvement process, we reserve the right to modify specifications and designs without giving prior notice. The figures may contain additional options.

### MAST

Duplex mast for lifting height of 4000 mm	●
Selection of duplex masts from 3500 to 6000 mm lifting height	●
Duplex mast for 4000 mm lifting height with free lift	●
Fork carrier with suspended fork arms, 2400 mm fork length	●
Side shift and distance adjustment of the forks	●
Individual arm adjustment	●

### WORKING LIGHTS

LED lighting system with 12 worklights	●
Rotating beacon	●
More work spotlights	●

### ELECTRONICS

Electric parking brake	●
Automatic engine stop when idling	●

### FURTHER MACHINE EQUIPMENT

Electro-hydraulically tiltable cab	●
External monitor for daily maintenance control	●
Automatic central lubrication system	●
Custom paint	●

# SANY

Quality Changes the World

**SANY EUROPE GmbH**  
Sany Allee 1  
50181 Bedburg, Germany  
Tel. +49 2272 90531 100  
Fax +49 2272 90531 109  
info@sanyeurope.com  
www.sanyeurope.com